

ARK

AGRICULTURE

SPILL CONTAINMENT

**IBC Bunds, Spill or Sump Pallets, Spill Trays,
Drum Bunds and Drum Pallets**



ARK Agriculture Ltd

Milbank House

Earls Colne Business Park

Earls Colne

Essex CO6 2NS

Tel: 01787 220560

Email: sales@arkagriculture.com

Website: www.ARKagriculture.com

Spill Containment

IBC Bund, Spill Pallet or Sump Pallets	2-16
IBC Bund user instructions	17-18
Spill Trays, Drum Bunds & Drum Pallets	19-27
Multi-Purpose Bunds, Generator Bunds	28-30
Standard Sized Bunds	31
Custom Built Bunds and Spill Trays	32-33

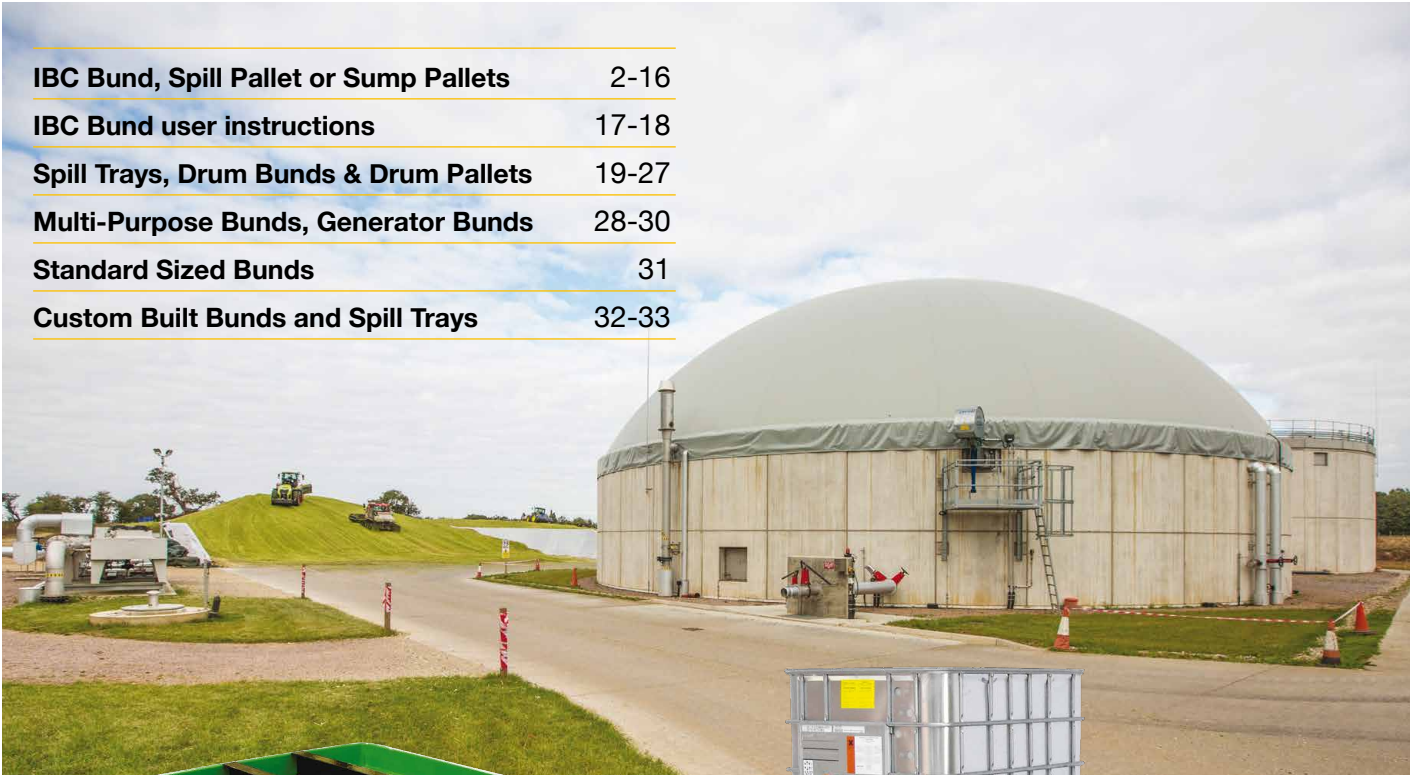

Spill Bund for Generator or Tanks



2 IBC Spill Bund



Drum Spill Pallets



IBC Spill Bund

For prices or to order visit: www.arkagriculture.com
or call **01787 220 560** to speak to our specialist team.

IBC Bund, Spill Pallet or Sump Pallet - ARK101

Spill containment for 1 x 1000 litre IBC.

Designed for the long term safe bunding of IBC's and suitable for all oils and 95% of chemicals, IBC Bund Spill Pallets catch leaks, drips and spills to help you comply with current oil and chemical storage regulations, and keep your storage areas clean.

Our product features:

- Tough reinforced composite construction - withstands the rigours of a working environment.
- Broad range chemical compatibility - no need to purchase a new unit if your storage use changes.
- Retains long term structural integrity.
- Lighter than steel or polyethylene - easily repositioned without risk of manual handling injury.
- Simply shaped - easily emptied or cleaned.
- No taps or drainage points to compromise the bund area.
- Large catchment area - our IBC bunds have twice the catchment area of some other products on the market.
- For internal or exterior use.

Benefits:

- Protects the workplace, environment and personnel.
- Designed for most sizes of IBC.
- Maintenance free.

Compliance:

- Compliant with 110% oil and chemical storage regulations avoid action from the Environmental Agency.

Colours

Blue RAL 5015, Yellow RAL 1003, Orange RAL 2009, Red RAL 3950, Green RAL 6029, Purple RAL 22C37,

We can manufacture in your corporate colour or any BS / RAL colour of your choice. Help to identify contents or hazards with colour.



ARK101

Spill containment for 1 x 1000 litre IBC.

Principal Material	GRP (Glass Reinforced Plastic)
Support Material	-
Dimensions	1670 x 1570 x 650mm
Regulation Capacity	1100 litres
Actual Capacity	1100+ litres
Maximum UDL	2000 kgs
Weight	approx. 45 kgs
Maximum size of IBC:	1270 length x 1100 width mm
Minimum size of IBC:	1110 length x 950 width mm
For ambient temperatures	-100°C to +80°C

Larger or smaller IBC's can be accommodated.

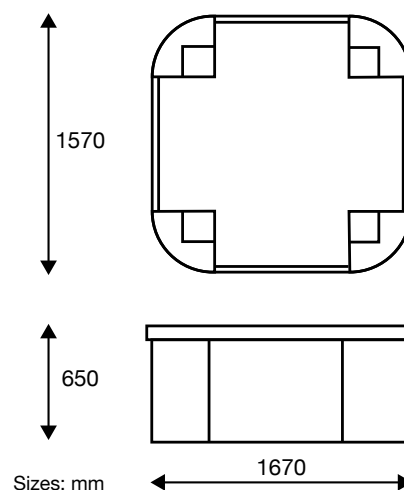

For prices or to order visit: www.arkagriculture.com
or call **01787 220 560** to speak to our specialist team.

ARK Agriculture Ltd,
Milbank House,
Earls Colne Business Park,
Earls Colne, Colchester,
Essex, CO6 2NS

IBC Bund, Spill Pallet or Sump Pallet - ARK101



ARK101-RP with removable platform

Spill containment for 1 x 1000 litre IBC.

The heavy duty anti slip gritted grating allows you to position an IBC without sliding. The grating can be removed so your bund can be emptied or cleaned with ease.

Principal Material	GRP (Glass Reinforced Plastic)
Support Material	Anti slip grating
Dimensions	1670 x 1570 x 657mm
Regulation Capacity	1100 litres
Actual Capacity	1100+ litres
Maximum UDL	2000 kgs
Weight	approx. 65 kgs
Maximum size of IBC:	1270 length x 1100 width mm
Minimum size of IBC:	1110 length x 950 width mm
For ambient temperatures	-100°C to +80°C

Larger or smaller IBC's can be accommodated.

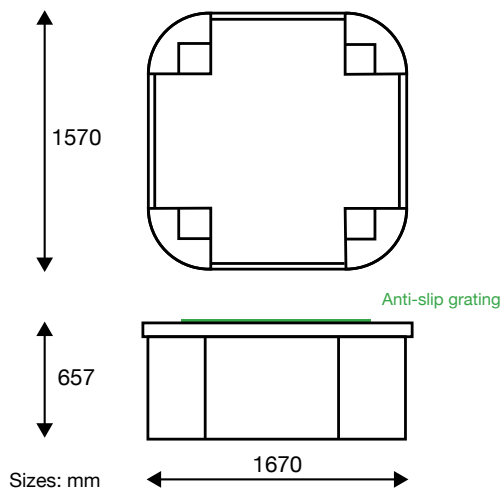

ARK101-FL with removable platform & forklift facility

Spill containment for 1 x 1000 litre IBC.

For ease of movement and positioning, with our forklift facility, bund and IBC can be moved together.

Principal Material	GRP (Glass Reinforced Plastic)
Support Material	Anti slip grating
Dimensions	1670 x 1570 x 782mm
Regulation Capacity	1100 litres
Actual Capacity	1100+ litres
Maximum UDL	2000 kgs
Weight	approx. 115 kgs
Maximum size of IBC:	1270 length x 1100 width mm
Minimum size of IBC:	1110 length x 950 width mm
For ambient temperatures	-100°C to +80°C

Larger or smaller IBC's can be accommodated.

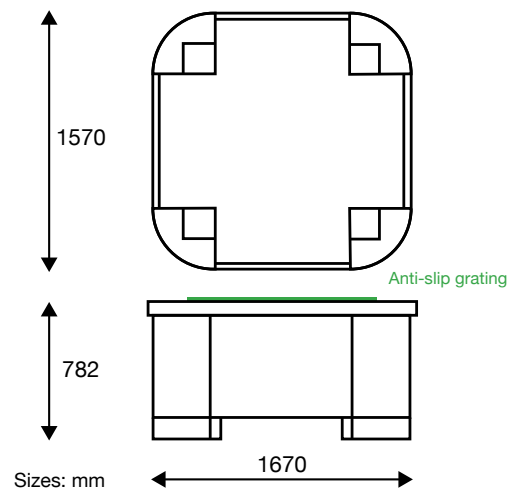

For prices or to order visit: www.arkagriculture.com
or call **01787 220 560** to speak to our specialist team.

ARK Agriculture Ltd,
Milbank House,
Earls Colne Business Park,
Earls Colne, Colchester,
Essex, CO6 2NS

IBC Bund, Spill Pallet or Sump Pallet - ARK102

Spill containment for 1 x 1000 litre IBC. With dispensing facility.

Designed for the long term safe bunding of IBC's and suitable for all oils and 95% of chemicals, IBC Bund Spill Pallets catch leaks, drips and spills to help you comply with current oil and chemical storage regulations, and keep your storage areas clean.

With unique drip tray feature

Specially designed for easy cleaning, the drip tray feature is unique to our Bund Spill Pallet. The tray catches leaks and small spills during dispensing operations in an easy to reach area, meaning you don't have to clean the entire bund floor.

Our product features:

- Tough reinforced composite construction - withstands the rigours of a working environment.
- Broad range chemical compatibility - no need to purchase a new unit if your storage use changes.
- Retains long term structural integrity.
- Lighter than steel or polyethylene - easily repositioned without risk of manual handling injury.
- Simply shaped - easily emptied or cleaned.
- No taps or drainage points to compromise the bund area.
- Large catchment area - our IBC bunds have twice the catchment area of some other products on the market.
- For internal or exterior use.

Benefits:

- Protects the workplace, environment and personnel.
- Designed for most sizes of IBC.
- Maintenance free.

Compliance:

- Compliant with 110% oil and chemical storage regulations avoid action from the Environmental Agency.

Colours

Blue RAL 5015, Yellow RAL 1003, Orange RAL 2009, Red RAL 3950, Green RAL 6029, Purple RAL 22C37,

We can manufacture in your corporate colour or any BS / RAL colour of your choice. Help to identify contents or hazards with colour.



ARK102 with drip tray.

Spill containment for 1 x 1000 litre IBC.

Principal Material	GRP (Glass Reinforced Plastic)
Support Material	-
Dimensions	1930 x 1570 x 650mm
Regulation Capacity	1100 litres
Actual Capacity	1100+ litres
Maximum UDL	2000 kgs
Weight	approx. 45 kgs
Maximum size of IBC:	1270 length x 1100 width mm
Minimum size of IBC:	1110 length x 950 width mm
For ambient temperatures	-100°C to +80°C

Larger or smaller IBC's can be accommodated.

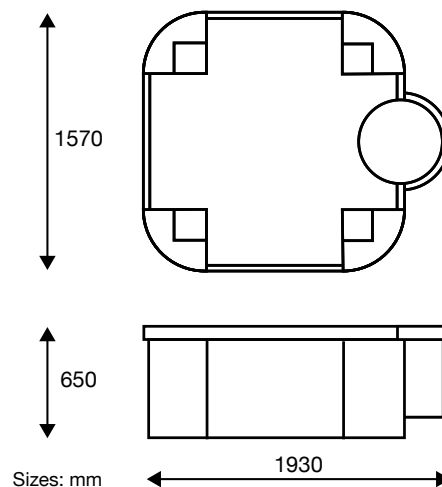

For prices or to order visit: www.arkagriculture.com
or call **01787 220 560** to speak to our specialist team.

ARK Agriculture Ltd,
Milbank House,
Earls Colne Business Park,
Earls Colne, Colchester,
Essex, CO6 2NS

IBC Bund, Spill Pallet or Sump Pallet - ARK102



ARK102-RP with drip tray, removable platform

Spill containment for 1 x 1000 litre IBC.

The heavy duty anti slip gritted grating allows you to position an IBC without sliding. The grating can be removed so your bund can be emptied or cleaned with ease.

Principal Material	GRP (Glass Reinforced Plastic)
Support Material	Anti slip grating
Dimensions	1930 x 1570 x 657mm
Regulation Capacity	1100 litres
Actual Capacity	1100+ litres
Maximum UDL	2000 kgs
Weight	approx. 65 kgs
Maximum size of IBC:	1270 length x 1100 width mm
Minimum size of IBC:	1110 length x 950 width mm
For ambient temperatures	-100°C to +80°C

Larger or smaller IBC's can be accommodated.

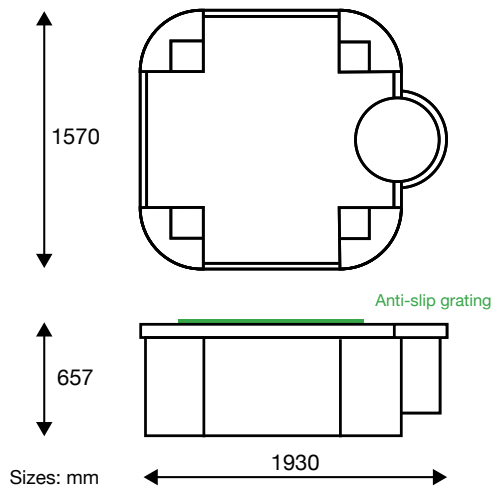

ARK102-FL with drip tray, removable platform, forklift facility

Spill containment for 1 x 1000 litre IBC.

For ease of movement and positioning, with our forklift facility, bund and IBC can be moved together.

Principal Material	GRP (Glass Reinforced Plastic)
Support Material	Anti slip grating
Dimensions	1930 x 1570 x 782mm
Regulation Capacity	1100 litres
Actual Capacity	1100+ litres
Maximum UDL	2000 kgs
Weight	approx. 115 kgs
Maximum size of IBC:	1270 length x 1100 width mm
Minimum size of IBC:	1110 length x 950 width mm
For ambient temperatures	-100°C to +80°C

Larger or smaller IBC's can be accommodated.

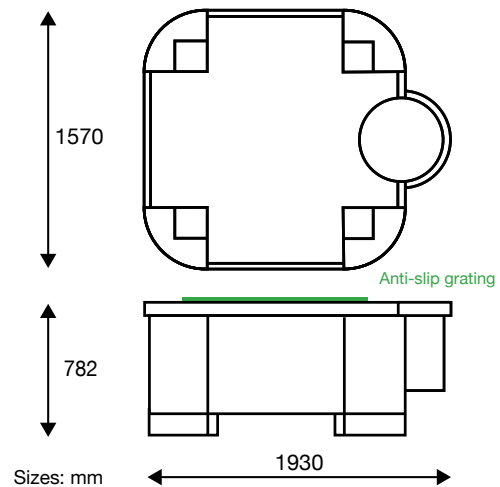

For prices or to order visit: www.arkagriculture.com
or call **01787 220 560** to speak to our specialist team.

ARK Agriculture Ltd,
Milbank House,
Earls Colne Business Park,
Earls Colne, Colchester,
Essex, CO6 2NS

IBC Bund, Spill Pallet or Sump Pallet for 2 IBC - ARK104

Spill containment for 2 x 1000 litre IBC's.

Designed for the long term safe bunding of IBC's and suitable for all oils and 95% of chemicals, IBC Bund Spill Pallets catch leaks, drips and spills to help you comply with current oil and chemical storage regulations, and keep your storage areas clean.

Our product features:

- Tough reinforced composite construction - withstands the rigours of a working environment.
- Broad range chemical compatibility - no need to purchase a new unit if your storage use changes.
- Retains long term structural integrity.
- Lighter than steel or polyethylene - easily repositioned without risk of manual handling injury.
- Simply shaped - easily emptied or cleaned.
- No taps or drainage points to compromise the bund area
- Large catchment area - our IBC bunds have twice the catchment area of some other products on the market.
- For internal or exterior use.

Benefits:

- Protects the workplace, environment and personnel.
- Designed for most sizes of IBC.
- Maintenance free.

Compliance:

- Compliant with 110% oil and chemical storage regulations avoid action from the Environmental Agency.

Colours

Blue RAL 5015, Yellow RAL 1003, Orange RAL 2009, Red RAL 3950, Green RAL 6029, Purple RAL 22C37,

We can manufacture in your corporate colour or any BS / RAL colour of your choice. Help to identify contents or hazards with colour.



ARK104 Double IBC Bund

Spill containment for 2 x 1000 litre IBC's.

Principal Material	GRP (Glass Reinforced Plastic)
Support Material	-
Dimensions	2810 x 1670 x 370mm
Regulation Capacity	1100 litres
Actual Capacity	1100+ litres
Maximum UDL	3000 kgs
Weight	approx. 60 kgs
Maximum size of IBC:	1270 length x 1100 width mm
Minimum size of IBC:	1110 length x 950 width mm
For ambient temperatures	-100°C to +80°C

Larger or smaller IBC's can be accommodated.

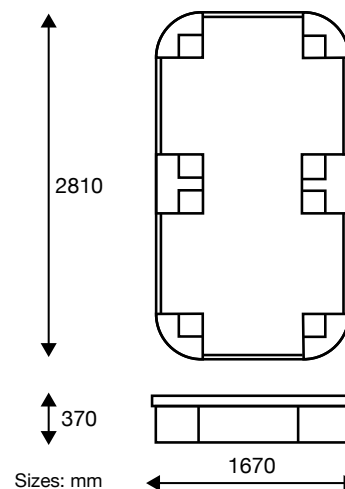

For prices or to order visit: www.arkagriculture.com
or call **01787 220 560** to speak to our specialist team.

ARK Agriculture Ltd,
Milbank House,
Earls Colne Business Park,
Earls Colne, Colchester,
Essex, CO6 2NS

IBC Bund, Spill Pallet or Sump Pallet for 2 IBC - ARK104



ARK104-RP with removable platform

Spill containment for 2 x 1000 litre IBC's.

The heavy duty anti slip gritted grating allows you to position IBCs without sliding. The grating can be removed so your bund can be emptied or cleaned with ease.

Principal Material	GRP (Glass Reinforced Plastic)
Support Material	Anti slip grating
Dimensions	2810 x 1670 x 377mm
Regulation Capacity	1100 litres
Actual Capacity	1100+ litres
Maximum UDL	3000 kgs
Weight	approx. 104 kgs
Maximum size of IBC:	1270 length x 1100 width mm
Minimum size of IBC:	1110 length x 950 width mm
For ambient temperatures	-100°C to +80°C

Larger or smaller IBC's can be accommodated.

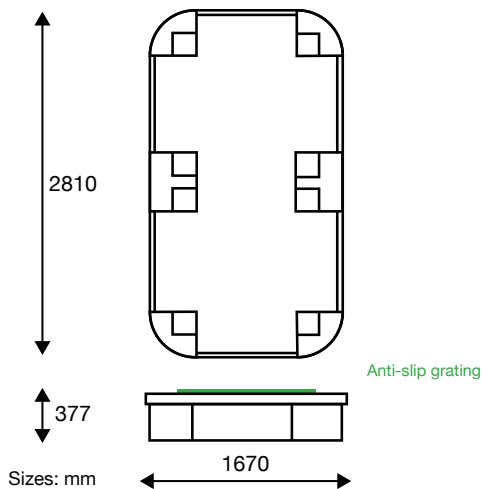

ARK104-FL with removable platform, forklift facility

Spill containment for 2 x 1000 litre IBC's.

With forklift facility, for ease of movement and positioning of spill bund.

Principal Material	GRP (Glass Reinforced Plastic)
Support Material	Anti slip grating
Dimensions	2810 x 1670 x 502mm
Regulation Capacity	1100 litres
Actual Capacity	1100+ litres
Maximum UDL	3000 kgs
Weight	approx. 134 kgs
Maximum size of IBC:	1270 length x 1100 width mm
Minimum size of IBC:	1110 length x 950 width mm
For ambient temperatures	-100°C to +80°C

Larger or smaller IBC's can be accommodated.

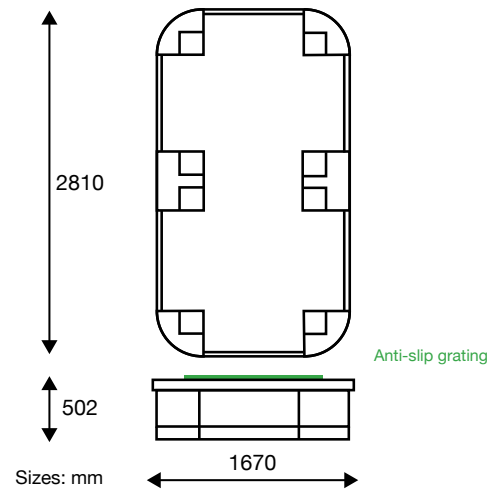

For prices or to order visit: www.arkagriculture.com
or call **01787 220 560** to speak to our specialist team.

ARK Agriculture Ltd,
Milbank House,
Earls Colne Business Park,
Earls Colne, Colchester,
Essex, CO6 2NS

IBC Bund, Spill Pallet or Sump Pallet for 2 IBC - ARK105

Spill containment for 2 x 1000 litre IBC. With dispensing facility.

Designed for the long term safe bunding of IBC's and suitable for all oils and 95% of chemicals, IBC Bund Spill Pallets catch leaks, drips and spills to help you comply with current oil and chemical storage regulations, and keep your storage areas clean.

With unique drip tray feature

Specially designed for easy cleaning, the drip tray feature is unique to our Bund Spill Pallet. The tray catches leaks and small spills during dispensing operations in an easy to reach area, meaning you don't have to clean the entire bund floor.

Our product features:

- Tough reinforced composite construction - withstands the rigours of a working environment.
- Broad range chemical compatibility - no need to purchase a new unit if your storage use changes.
- Retains long term structural integrity.
- Lighter than steel or polyethylene - easily repositioned without risk of manual handling injury.
- Simply shaped - easily emptied or cleaned.
- No taps or drainage points to compromise the bund area.
- Large catchment area - our IBC bunds have twice the catchment area of some other products on the market.
- For internal or exterior use.

Benefits:

- Protects the workplace, environment and personnel.
- Designed for most sizes of IBC.
- Maintenance free.

Compliance:

- Compliant with 110% oil and chemical storage regulations avoid action from the Environmental Agency.

Colours

Blue RAL 5015, Yellow RAL 1003, Orange RAL 2009, Red RAL 3950, Green RAL 6029, Purple RAL 22C37,

We can manufacture in your corporate colour or any BS / RAL colour of your choice. Help to identify contents or hazards with colour.



ARK105 Double IBC Bund with drip tray.

Spill containment for 2 x 1000 litre IBC.

Principal Material	GRP (Glass Reinforced Plastic)
Support Material	-
Dimensions	2810 x 1930 x 470mm
Regulation Capacity	1100 litres
Actual Capacity	1100+ litres
Maximum UDL	3000 kgs
Weight	approx. 65 kgs
Maximum size of IBC:	1270 length x 1100 width mm
Minimum size of IBC:	1110 length x 950 width mm
For ambient temperatures	-100°C to +80°C

Larger or smaller IBC's can be accommodated.

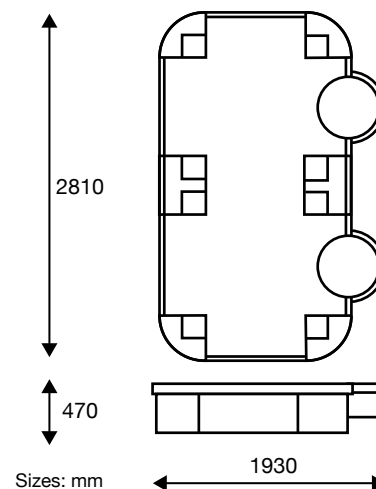

For prices or to order visit: www.arkagriculture.com
or call **01787 220 560** to speak to our specialist team.

ARK Agriculture Ltd,
Milbank House,
Earls Colne Business Park,
Earls Colne, Colchester,
Essex, CO6 2NS

IBC Bund, Spill Pallet or Sump Pallet for 2 IBC - ARK105



ARK105-RP with drip tray, removable platform

Spill containment for 2 x 1000 litre IBC.

The heavy duty anti slip gritted grating allows you to position IBCs without sliding. The grating can be removed so your bund can be emptied or cleaned with ease.

Principal Material	GRP (Glass Reinforced Plastic)
Support Material	Anti slip grating
Dimensions	2810 x 1930 x 477mm
Regulation Capacity	1100 litres
Actual Capacity	1100+ litres
Maximum UDL	3000 kgs
Weight	approx. 109 kgs
Maximum size of IBC:	1270 length x 1100 width mm
Minimum size of IBC:	1110 length x 950 width mm
For ambient temperatures	-100°C to +80°C

Larger or smaller IBC's can be accommodated.

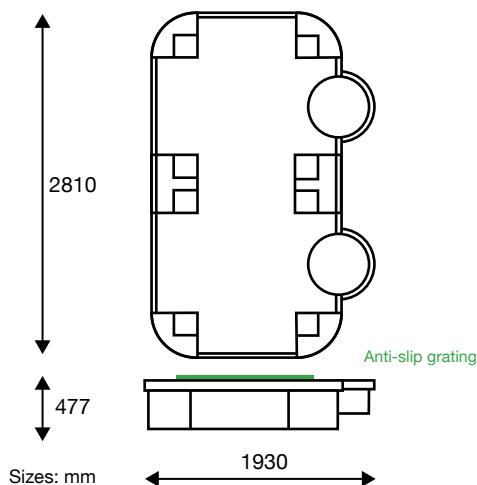

ARK105-FL with drip tray, removable platform, forklift facility

Spill containment for 2 x 1000 litre IBC.

With forklift facility, for ease of movement and positioning of spill bund.

Principal Material	GRP (Glass Reinforced Plastic)
Support Material	Anti slip grating
Dimensions	2810 x 1930 x 602mm
Regulation Capacity	1100 litres
Actual Capacity	1100+ litres
Maximum UDL	3000 kgs
Weight	approx. 139 kgs
Maximum size of IBC:	1270 length x 1100 width mm
Minimum size of IBC:	1110 length x 950 width mm
For ambient temperatures	-100°C to +80°C

Larger or smaller IBC's can be accommodated.

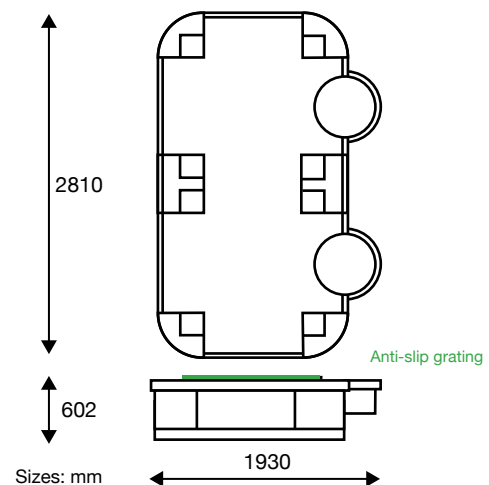

For prices or to order visit: www.arkagriculture.com
or call **01787 220 560** to speak to our specialist team.

ARK Agriculture Ltd,
Milbank House,
Earls Colne Business Park,
Earls Colne, Colchester,
Essex, CO6 2NS

IBC Bund, Spill Pallet or Sump Pallet for 4 IBC - ARK109

Spill containment for 4 x 1000 litre IBC.

Designed for the long term safe bunding of IBC's and suitable for all oils and 95% of chemicals, IBC Bund Spill Pallets catch leaks, drips and spills to help you comply with current oil and chemical storage regulations, and keep your storage areas clean.

Space saver - store up to 4 IBC tanks

A cost effective IBC storage solution: the tough reinforced composite construction means you can store up to four IBC tanks on one unit, avoiding the cost of buying multiple units. Designed for most sizes of IBC.

Our product features:

- Tough reinforced composite construction - withstands the rigours of a working environment.
- Broad range chemical compatibility - no need to purchase a new unit if your storage use changes.
- Retains long term structural integrity.
- Lighter than steel or polyethylene - easily repositioned without risk of manual handling injury.
- Simply shaped - easily emptied or cleaned.
- No taps or drainage points to compromise the bund area.
- Large catchment area - our IBC bunds have twice the catchment area of some other products on the market.
- For internal or exterior use.

Benefits:

- Protects the workplace, environment and personnel.
- Designed for most sizes of IBC.
- Maintenance free.

Compliance:

- Compliant with 110% oil and chemical storage regulations avoid action from the Environmental Agency.

Colours

Blue RAL 5015, Yellow RAL 1003, Orange RAL 2009, Red RAL 3950, Green RAL 6029, Purple RAL 22C37,

We can manufacture in your corporate colour or any BS / RAL colour of your choice. Help to identify contents or hazards with colour.



ARK109-RP with removable platform

Spill containment for 4 x 1000 litre IBC.

The heavy duty anti slip gritted grating allows you to position IBCs without sliding. The grating can be removed so your bund can be emptied or cleaned with ease.

Principal Material	GRP (Glass Reinforced Plastic)
Support Material	Anti slip grating
Dimensions	2810 x 1670 x 370mm
Regulation Capacity	1100 litres
Actual Capacity	1100+ litres
Maximum UDL	6000 kgs
Weight	approx. 119 kgs
Maximum size of IBC:	1270 length x 1100 width mm
Minimum size of IBC:	1110 length x 950 width mm
For ambient temperatures	-100°C to +80°C

Larger or smaller IBC's can be accommodated.

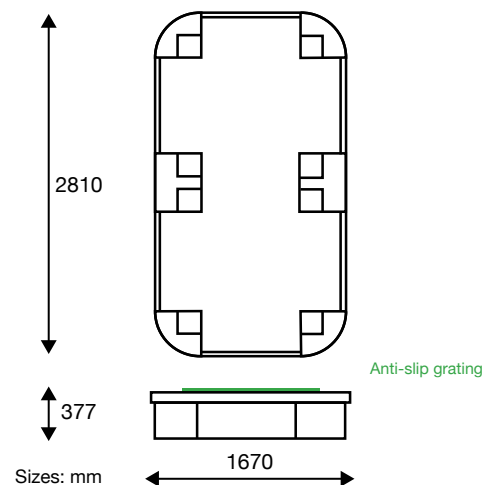

For prices or to order visit: www.arkagriculture.com
or call **01787 220 560** to speak to our specialist team.

IBC Bund, Spill Pallet or Sump Pallet for 4 IBC - ARK110

Spill containment for 4 x 1000 litre IBC.

Designed for the long term safe bunding of IBC's and suitable for all oils and 95% of chemicals, IBC Bund Spill Pallets catch leaks, drips and spills to help you comply with current oil and chemical storage regulations, and keep your storage areas clean.

Space saver - store up to 4 IBC tanks

A cost effective IBC storage solution: the tough reinforced composite construction means you can store up to four IBC tanks on one unit, avoiding the cost of buying multiple units. Designed for most sizes of IBC.

With unique drip tray feature

Specially designed for easy cleaning, the drip catches leaks and small spills during dispensing operations in an easy to reach area, so you don't have to clean the entire bund floor.

Our product features:

- Tough reinforced composite construction - withstands the rigours of a working environment.
- Broad range chemical compatibility - no need to purchase a new unit if your storage use changes.
- Retains long term structural integrity.
- Lighter than steel or polyethylene - easily repositioned without risk of manual handling injury.
- Simply shaped - easily emptied or cleaned.
- No taps or drainage points to compromise the bund area.
- Large catchment area - our IBC bunds have twice the catchment area of some other products on the market.
- For internal or exterior use.

Benefits:

- Protects the workplace, environment and personnel.
- Designed for most sizes of IBC.
- Maintenance free.

Compliance:

- Compliant with 110% oil and chemical storage regulations avoid action from the Environmental Agency.

Colours

We can manufacture in your corporate colour or any other colour of your choice. Help to identify IBC contents or hazards with your Bund colour.

Blue RAL 5015, Yellow RAL 1003, Orange RAL 2009, Red RAL 3950, Green RAL 6029, Purple RAL 22C37, Custom Colour: in any BS / RAL colour.



ARK110-RP with drip tray, removable platform

Spill containment for 4 x 1000 litre IBC.

The heavy duty anti slip gritted grating allows you to position IBCs without sliding. The grating can be removed so your bund can be emptied or cleaned with ease.

Principal Material	GRP (Glass Reinforced Plastic)
Support Material	Anti slip grating
Dimensions	2810 x 1930 x 470mm
Regulation Capacity	1100 litres
Actual Capacity	1100+ litres
Maximum UDL	6000 kgs
Weight	approx. 119 kgs
Maximum size of IBC:	1270 length x 1100 width mm
Minimum size of IBC:	1110 length x 950 width mm
For ambient temperatures	-100°C to +80°C

Larger or smaller IBC's can be accommodated.

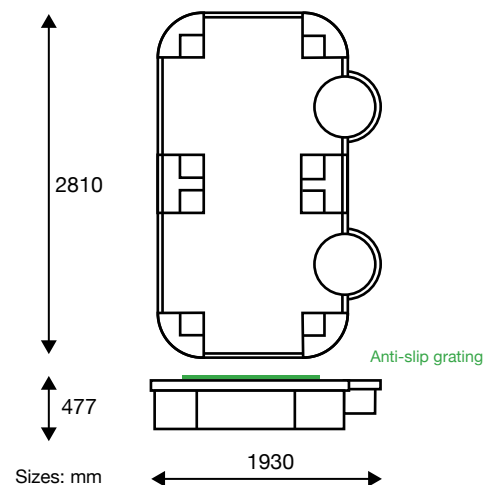

For prices or to order visit: www.arkagriculture.com
or call **01787 220 560** to speak to our specialist team.

ARK Agriculture Ltd,
Milbank House,
Earls Colne Business Park,
Earls Colne, Colchester,
Essex, CO6 2NS

IBC Bund, Spill Pallet or Sump Pallet for 6 IBC - ARK106

Storage and spill containment for 6 x 1000 litre IBC.

Designed for the long term safe bunding of IBC's and suitable for all oils and 95% of chemicals, IBC Bund Spill Pallets catch leaks, drips and spills to help you comply with current oil and chemical storage regulations, and keep your storage areas clean.

Space saver - store up to 6 IBC tanks

Our multiple IBC Bunds are very effective space savers where floor space is at a premium, and easy access to your IBC tanks is required.

Our product features:

- Bund up to 6 IBC's on 2.5m x 1.75m of floor space.
- Cost effective IBC storage: store up to six IBC tanks on one unit, avoiding the cost of buying multiple units.
- Tough reinforced composite construction - withstands the rigours of a working environment.
- Broad range chemical compatibility - no need to purchase a new unit if your storage use changes.
- Retains long term structural integrity.
- Simply shaped - easily emptied or cleaned.
- Large catchment area - our IBC bunds have twice the catchment area of some other products on the market.
- For internal or exterior use.

Benefits:

- Protects the workplace, environment and personnel.
- Designed for most sizes of IBC.
- Maintenance free.

Compliance:

- Compliant with 110% oil and chemical storage regulations avoid action from the Environmental Agency.

Colour

Standard colour Blue RAL 5015.



ARK106 with removable platform

Storage and spill containment for 6 x 1000 litre IBC.

The specially designed fibreglass construction is simply shaped with a removable grating support surface, so your bund can be easily emptied or cleaned.

The heavy duty anti slip gritted grating allows you to position your IBC units with ease.

Principal Material	GRP (Glass Reinforced Plastic)
Support Material	Anti slip grating, steel supports
Dimensions	2500 x 1750 x 500mm
Regulation Capacity	1500 litres
Actual Capacity	1755 litres
Maximum UDL	7200 kgs
Weight	approx. 250 kgs
For ambient temperatures	-100°C to +80°C

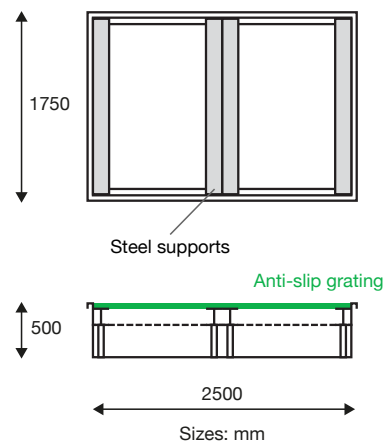

For prices or to order visit: www.arkagriculture.com
or call **01787 220 560** to speak to our specialist team.

IBC Bund, Spill Pallet or Sump Pallet for 6 IBC - ARK107

Storage and spill containment for 6 x 1000 litre IBC.

Designed for the long term safe bunding of IBC's and suitable for all oils and 95% of chemicals, IBC Bund Spill Pallets catch leaks, drips and spills to help you comply with current oil and chemical storage regulations, and keep your storage areas clean.

Space saver - store up to 6 IBC tanks

Our multiple IBC Bunds are very effective space savers where floor space is at a premium, and easy access to your IBC tanks is required.

Our product features:

- Bund up to 6 IBC's on 3.5m x 1.75m of floor space.
- Cost effective IBC storage: store up to six IBC tanks on one unit, avoiding the cost of buying multiple units.
- Tough reinforced composite construction - withstands the rigours of a working environment.
- Broad range chemical compatibility - no need to purchase a new unit if your storage use changes.
- Retains long term structural integrity.
- Simply shaped - easily emptied or cleaned.
- Large catchment area - our IBC bunds have twice the catchment area of some other products on the market.
- For internal or exterior use.

Benefits:

- Protects the workplace, environment and personnel.
- Designed for most sizes of IBC.
- Maintenance free.

Compliance:

- Compliant with 110% oil and chemical storage regulations avoid action from the Environmental Agency.

Colour

Standard colour Blue RAL 5015.



ARK107 with removable platform

Storage and spill containment for 6 x 1000 litre IBC.

The specially designed fibreglass construction is simply shaped with a removable grating support surface, so your bund can be easily emptied or cleaned.

The heavy duty anti slip gritted grating allows you to position your IBC units with ease.

Principal Material	GRP (Glass Reinforced Plastic)
Support Material	Anti slip grating, steel supports
Dimensions	3500mm x 1750mm x 500mm
Regulation Capacity	1500 litres
Actual Capacity	2475 litres
Maximum UDL	9900 kgs
Weight	approx. 390 kgs
For ambient temperatures	-100°C to +80°C

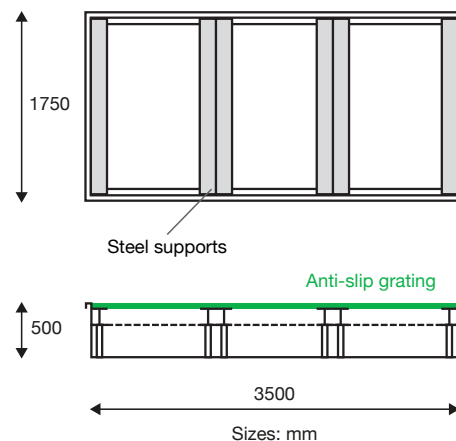

For prices or to order visit: www.arkagriculture.com
or call **01787 220 560** to speak to our specialist team.

ARK Agriculture Ltd,
Milbank House,
Earls Colne Business Park,
Earls Colne, Colchester,
Essex, CO6 2NS

IBC Bund, Spill Pallet or Sump Pallet for 8 IBC - ARK108

Storage and spill containment for 8 x 1000 litre IBC.

Designed for the long term safe bunding of IBC's and suitable for all oils and 95% of chemicals, IBC Bund Spill Pallets catch leaks, drips and spills to help you comply with current oil and chemical storage regulations, and keep your storage areas clean.

Space saver - store up to 8 IBC tanks

Our multiple IBC Bunds are very effective space savers where floor space is at a premium, and easy access to your IBC tanks is required.

Our product features:

- Bund up to 8 IBC's on 4.5m x 1.75m of floor space.
- Cost effective IBC storage: store up to eight IBC tanks on one unit, avoiding the cost of buying multiple units.
- Tough reinforced composite construction - withstands the rigours of a working environment.
- Broad range chemical compatibility - no need to purchase a new unit if your storage use changes.
- Retains long term structural integrity.
- Simply shaped - easily emptied or cleaned.
- Large catchment area - our IBC bunds have twice the catchment area of some other products on the market.
- For internal or exterior use.

Benefits:

- Protects the workplace, environment and personnel.
- Designed for most sizes of IBC.
- Maintenance free.

Compliance:

- Compliant with 110% oil and chemical storage regulations avoid action from the Environmental Agency.

Colour

Standard colour Blue RAL 5015.



ARK108 with removable platform

Storage and spill containment for 8 x 1000 litre IBC.

The specially designed fibreglass construction is simply shaped with a removable grating support surface, so your bund can be easily emptied or cleaned.

The heavy duty anti slip gritted grating allows you to position your IBC units with ease.

Principal Material	GRP (Glass Reinforced Plastic)
Support Material	Anti slip grating, steel supports
Dimensions	4500mm x 1750mm x 500mm
Regulation Capacity	2000 litres
Actual Capacity	3160 litres
Maximum UDL	3,200 kgs
Weight	approx. 520 kgs
For ambient temperatures	-100°C to +80°C

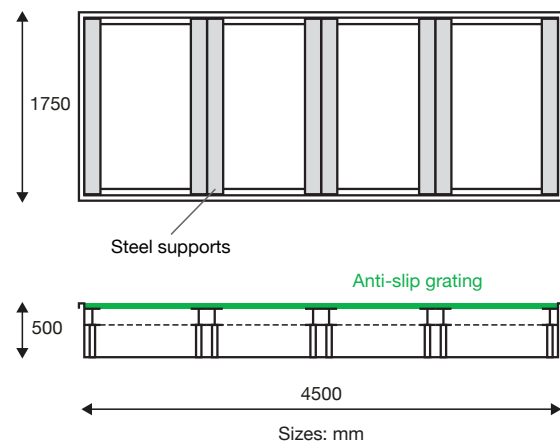

For prices or to order visit: www.arkagriculture.com
or call **01787 220 560** to speak to our specialist team.

ARK Agriculture Ltd,
Milbank House,
Earls Colne Business Park,
Earls Colne, Colchester,
Essex, CO6 2NS

IBC Bund, Spill Pallet or Sump Pallet for 9 IBC - ARK107-9

Storage and spill containment for 9 x 1000 litre IBC.

Designed for the long term safe bunding of IBC's and suitable for all oils and 95% of chemicals, IBC Bund Spill Pallets catch leaks, drips and spills to help you comply with current oil and chemical storage regulations, and keep your storage areas clean.

Space saver - store up to 9 IBC tanks

Our multiple IBC Bunds are very effective space savers where floor space is at a premium, and easy access to your IBC tanks is required.

Our product features:

- Bund up to 9 IBC's on 3.5m x 1.75m of floor space.
- Cost effective IBC storage: store up to nine IBC tanks on one unit, avoiding the cost of buying multiple units.
- Tough reinforced composite construction - withstands the rigours of a working environment.
- Broad range chemical compatibility - no need to purchase a new unit if your storage use changes.
- Retains long term structural integrity.
- Simply shaped - easily emptied or cleaned.
- Large catchment area - our IBC bunds have twice the catchment area of some other products on the market.
- For internal or exterior use.

Benefits:

- Protects the workplace, environment and personnel.
- Designed for most sizes of IBC.
- Maintenance free.

Compliance:

- Compliant with 110% oil and chemical storage regulations avoid action from the Environmental Agency.

Colour

Standard colour Blue RAL 5015.



ARK107-9 with removable platform

Storage and spill containment for 9 x 1000 litre IBC.

The specially designed fibreglass construction is simply shaped with a removable grating support surface, so your bund can be easily emptied or cleaned.

The heavy duty anti slip gritted grating allows you to position your IBC units with ease.

Principal Material	GRP (Glass Reinforced Plastic)
Support Material	Anti slip grating, steel supports
Dimensions	3500mm x 1750mm x 500mm
Regulation Capacity	2250 litres
Actual Capacity	2475 litres
Maximum UDL	9900 kgs
Weight	approx. 390 kgs
For ambient temperatures	-100°C to +80°C

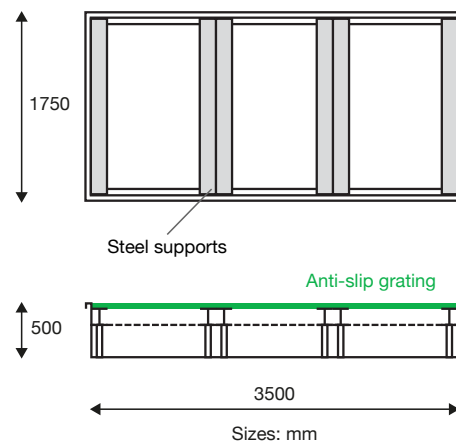

For prices or to order visit: www.arkagriculture.com
or call **01787 220 560** to speak to our specialist team.

IBC Bund, Spill Pallet or Sump Pallet for 12 IBC - ARK108-12

Storage and spill containment for 12 x 1000 litre IBC.

Designed for the long term safe bunding of IBC's and suitable for all oils and 95% of chemicals, IBC Bund Spill Pallets catch leaks, drips and spills to help you comply with current oil and chemical storage regulations, and keep your storage areas clean.

Space saver - store up to 12 IBC tanks

Our multiple IBC Bunds are very effective space savers where floor space is at a premium, and easy access to your IBC tanks is required.

Our product features:

- Bund up to 12 IBC's on 4.5m x 1.75m of floor space.
- Cost effective IBC storage: store up to twelve IBC tanks on one unit, avoiding the cost of buying multiple units.
- Tough reinforced composite construction - withstands the rigours of a working environment.
- Broad range chemical compatibility - no need to purchase a new unit if your storage use changes.
- Retains long term structural integrity.
- Simply shaped - easily emptied or cleaned.
- Large catchment area - our IBC bunds have twice the catchment area of some other products on the market.
- For internal or exterior use.

Benefits:

- Protects the workplace, environment and personnel.
- Designed for most sizes of IBC.
- Maintenance free.

Compliance:

- Compliant with 110% oil and chemical storage regulations avoid action from the Environmental Agency.

Colour

Standard colour Blue RAL 5015.



ARK108-12 with removable platform

Storage and spill containment for 12 x 1000 litre IBC.

The specially designed fibreglass construction is simply shaped with a removable grating support surface, so your bund can be easily emptied or cleaned.

The heavy duty anti slip gritted grating allows you to position your IBC units with ease.

Principal Material	GRP (Glass Reinforced Plastic)
Support Material	Anti slip grating, steel supports
Dimensions	4500mm x 1750mm x 500mm
Regulation Capacity	3000 litres
Actual Capacity	3160 litres
Maximum UDL	13,200 kgs
Weight	approx. 520 kgs
For ambient temperatures	-100°C to +80°C

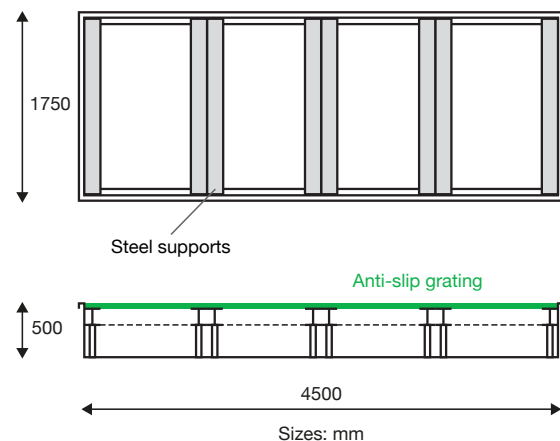

For prices or to order visit: www.arkagriculture.com
or call **01787 220 560** to speak to our specialist team.

ARK Agriculture Ltd,
Milbank House,
Earls Colne Business Park,
Earls Colne, Colchester,
Essex, CO6 2NS

User Health & Safety Instructions for ARK101, 102, 104, 105, 109, 110

IBC Bunds & Spill Pallets will give many years of service by following our guidelines:

Siting the IBC Bund

The IBC Bund should be sited and fully supported on a flat uniform level surface of a sufficiently strong and stable nature, and should be clean of stones and any other objects. A bed of soft sand cement mix can be used if the site is uneven.

Loading the IBC Spill Containment Bundstand

Forklift users should be instructed to lower the IBC unit as carefully and as level as possible on the Bund.

The IBC unit must sit on the recessed pads, avoid lowering onto elevated surfaces. The forks should be withdrawn free of snagging the IBC Bund rim or any part of the IBC unit.

Forklift users should be made aware that the single IBC Bund is not square and the IBC unit should be loaded correctly. The IBC unit nozzle should face toward the narrowest side. IBC Bunds with a drain off bucket facility cannot be loaded from the bucket side.

The IBC unit should not be loaded onto the Bund while the Bund is on a wooden pallet.

Spillages

In the event of a spill and in harmony with good housekeeping, cleanups should occur immediately and any residual liquid neutralised. However, data sheets should be consulted and the health and safety officer or responsible person should supervise all cleanups. Waste should be disposed of in accord with the manufacturer's direction.

The units are designed/supplied for secondary containment of spillage, and not for primary containment unless otherwise agreed in writing.

Use

The IBC Bund is designed to cope with a variety of environments and is suitable for 95% of all liquids to be stored. Please refer to our chemical resistance chart showing the range of liquids that can be safely banded: www.arkagriculture.com/pdf/chemical-resistance.pdf

When drawing from the IBC unit directly into a container, sensible practices should be followed such as not overfilling the container, not leaving the container whilst being filled, the wearing of appropriate gloves, etc.

The filled container should not be removed from the IBC Bund without first making sure the IBC valve is turned off and not leaking fluid.

Storage

Thoroughly clean and store on a flat surface.

Moving the IBC Spill Containment Bund

The Bund (without IBC) can be lifted quite comfortably by two healthy personnel. However, it is recommended that when moving the location of the Bund it is manhandled onto a pallet and moved by forklift. If relocating please refer to 'Siting the IBC Bund'.

When manhandling the Bund sensible lifting practices should be employed:

- Do not:-
- a) Drag the IBC Bund
 - b) Forklift without a pallet (unless the Bund has added forklift facility)

Under no circumstances should any Bund be moved while accommodating an IBC unit.



For prices or to order visit: www.arkagriculture.com
or call **01787 220 560** to speak to our specialist team.

User Health & Safety Instructions for ARK106, 107, 108

IBC Bunds & Spill Pallets will give many years of service by following our guidelines:

Siting the IBC Bund

The IBC Bund should be sited and fully supported on a flat uniform level surface of a sufficiently strong and stable nature, and should be clean of stones and any other objects.

Loading the IBC Spill Containment Bundstand

Forklift users should be instructed to lower the IBC unit as carefully and as level as possible on the Bund, centrally over the grating supports.

The forks should be withdrawn free of snagging the IBC Bund rim or any part of the IBC unit.

The IBC unit nozzle should face toward the front.

Spillages

In the event of a spill and in harmony with good housekeeping, cleanups should occur immediately and any residual liquid neutralised. However, data sheets should be consulted and the Health and Safety Officer or responsible person should supervise all cleanups. Waste should be disposed of in accord with the manufacturers direction.

The units are designed/supplied for secondary containment of spillage, and not for primary containment unless otherwise agreed in writing.

Use

The IBC Bund is designed to cope with a variety of environments and is suitable for 95% of all liquids to be stored. Please refer to our chemical resistance chart showing the range of liquids that can be safely banded: <http://www.suigeneris.co.uk/pdfs/Spill-Containment-Chemical-Resistance-Charts.pdf>



ARK108-12 Bund up to 12 x 1000 litre IBCs.



ARK107-9 Bund up to 9 x 1000 litre IBCs.

For prices or to order visit: www.arkagriculture.com
or call **01787 220 560** to speak to our specialist team.

1 Drum Spill Tray - ARK201

25% spill capacity for 1 x Drum.

Suitable for all oils and 95% of chemicals, One Drum Spill Trays catch leaks, drips and spills to help you comply with current oil and chemical storage regulations, and keep your storage areas clean.

With unique anti slip grating support surface

The specially designed fibreglass construction is simply shaped with a removable grating support surface, so your spill tray can be easily emptied or cleaned.

The heavy-duty anti slip gritted grating allows you to position your drums without sliding.

Our product features:

- Tough reinforced composite construction - withstands the rigours of a working environment.
- Broad range chemical compatibility - no need to purchase a new unit if storage use changes.
- Retains long term structural integrity.
- Lighter than steel or polyethylene - easily repositioned without risk of manual handling injury.
- Simply shaped - easily emptied or cleaned.
- Heavy-duty anti slip support surface - position drums without sliding.
- For internal or exterior use.

Benefits:

- Protects the workplace, environment and personnel.
- Maintenance free.

Colour

Blue RAL 5015 + Green RAL 6029 grating.

Custom colour

We can manufacture in your corporate colour or any BS / RAL colour of your choice. Help to identify contents or hazards with colour. A reduced guarantee may apply on some colours.

(Custom colours not available for the grating support.)



ARK201 with anti slip grating support
25% spill capacity for 1 x Drum.

Principal Material	GRP (Glass Reinforced Plastic)
Support Material	Anti slip grating
Dimensions	850 x 850 x 160mm
Capacity	55 litres
Maximum Loading	500 kgs
Weight	approx. 20 kgs
For ambient temperatures	-50°C to +80°C

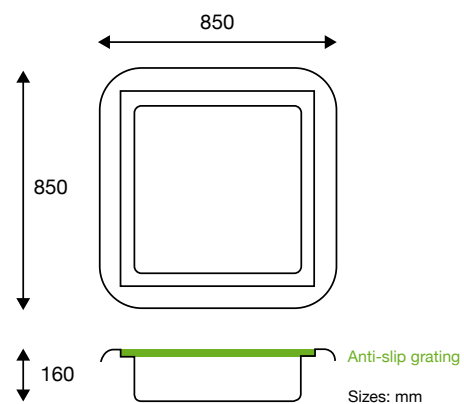

For prices or to order visit: www.arkagriculture.com
or call **01787 220 560** to speak to our specialist team.

ARK Agriculture Ltd,
Milbank House,
Earls Colne Business Park,
Earls Colne, Colchester,
Essex, CO6 2NS

1 Drum Spill Pallet with forklift facility - ARK201-FL

25% spill capacity for 1 x Drum.

Suitable for all oils and 95% of chemicals, One Drum Spill Trays catch leaks, drips and spills to help you comply with current oil and chemical storage regulations, and keep your storage areas clean.

With unique forklift facility & anti slip grating features

Specially designed to aid the transportation of your drums, the fibreglass construction is much stronger than polyethylene, both spill pallet and drum can be moved together safely. When using a forklift drum grabber attachment, drums can be positioned without sliding, thanks to the specially gritted grating surface.

Our product features:

- Tough reinforced composite construction - withstands the rigours of a working environment.
- Broad range chemical compatibility - no need to purchase a new unit if storage use changes.
- Retains long term structural integrity.
- Simply shaped - easily emptied or cleaned.
- Heavy-duty anti slip support surface - position drums without sliding.
- Forklift friendly - bund and drums can be lifted together.
- For internal or exterior use.

Benefits:

- Protects the workplace, environment and personnel.
- Maintenance free.

Colour

Blue RAL 5015 + Green RAL 6029 grating.

Custom colour

We can manufacture in your corporate colour or any BS / RAL colour of your choice. Help to identify contents or hazards with colour. A reduced guarantee may apply on some colours.

(Custom colours not available for the grating support.)



ARK102-FL with anti slip grating support, forklift facility
25% spill capacity for 1 x Drum.

Principal Material	GRP (Glass Reinforced Plastic)
Support Material	Anti slip grating
Dimensions	850 x 850 x 290mm
Capacity	55 litres
Maximum Loading	500 kgs
Weight	approx. 25 kgs
For ambient temperatures	-50°C to +80°C

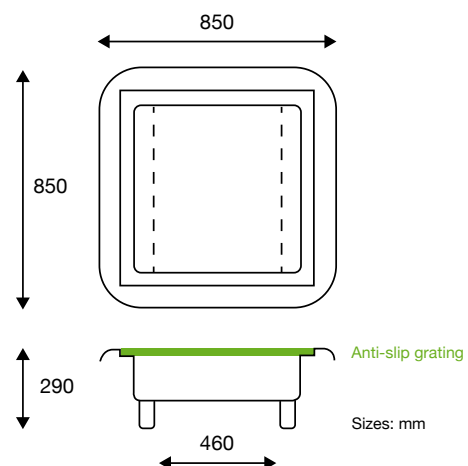

For prices or to order visit: www.arkagriculture.com
or call **01787 220 560** to speak to our specialist team.

ARK Agriculture Ltd,
Milbank House,
Earls Colne Business Park,
Earls Colne, Colchester,
Essex, CO6 2NS

2 Drum Bund - ARK202

Spill containment for 2 x 205 litre Drums.

Designed for the long term safe bunding of drums and suitable for all oils and 95% of chemicals, Drum Bunds catch leaks, drips and spills to help you comply with current oil and chemical storage regulations, and keep your storage areas clean.

With unique anti slip grating support surface

The specially designed fibreglass construction is simply shaped with a removable grating support surface, so your bund can be easily emptied or cleaned.

The heavy-duty anti slip gritted grating allows you to position your drums without sliding.

Our product features:

- Tough reinforced composite construction - withstands the rigours of a working environment.
- Broad range chemical compatibility - no need to purchase a new unit if storage use changes.
- Retains long term structural integrity.
- Lighter than steel or polyethylene - easily repositioned without risk of manual handling injury.
- Simply shaped - easily emptied or cleaned.
- Heavy-duty anti slip support surface - position drums without sliding.
- For internal or exterior use.

Benefits:

- Protects the workplace, environment and personnel.
- Maintenance free.

Colour

Blue RAL 5015 + Green RAL 6029 grating.

Custom colour

We can manufacture in your corporate colour or any BS / RAL colour of your choice. Help to identify contents or hazards with colour. A reduced guarantee may apply on some colours.

(Custom colours not available for the grating support.)



ARK202 with anti slip grating support
Spill containment for 2 x 205 litre Drums.

Principal Material	GRP (Glass Reinforced Plastic)
Support Material	Anti slip grating
Dimensions	1380 x 850 x 400mm
Capacity	220 litres
Actual Capacity	270 litres
Maximum Loading	1000 kgs
Weight	approx. 30 kgs
For ambient temperatures	-50°C to +80°C

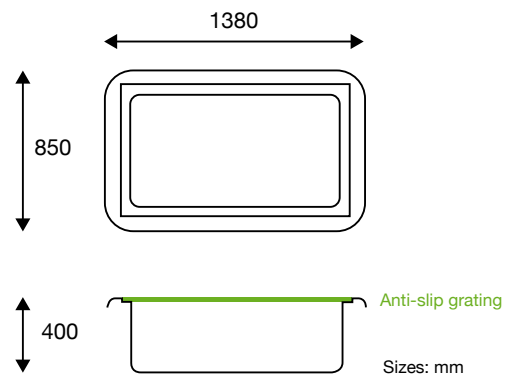

For prices or to order visit: www.arkagriculture.com
or call **01787 220 560** to speak to our specialist team.

ARK Agriculture Ltd,
Milbank House,
Earls Colne Business Park,
Earls Colne, Colchester,
Essex, CO6 2NS

2 Drum Spill Pallet with forklift facility - ARK202-FL

Spill containment for 2 x 205 litre Drums.

Designed for the long term safe bunding of drums and suitable for all oils and 95% of chemicals, Drum Bunds catch leaks, drips and spills to help you comply with current oil and chemical storage regulations, and keep your storage areas clean.

With unique forklift facility & anti slip grating features

Specially designed to aid the transportation of your drums, the fibreglass construction is much stronger than polyethylene, both spill pallet and drums can be moved together safely. When using a forklift drum grabber attachment, drums can be positioned without sliding, thanks to the specially gritted grating surface.

Our product features:

- Tough reinforced composite construction - withstands the rigours of a working environment.
- Broad range chemical compatibility - no need to purchase a new unit if storage use changes.
- Retains long term structural integrity.
- Simply shaped - easily emptied or cleaned.
- Heavy-duty anti slip support surface - position drums without sliding.
- Forklift friendly - bund and drums can be lifted together.
- For internal or exterior use.

Benefits:

- Protects the workplace, environment and personnel.
- Maintenance free.

Colour

Blue RAL 5015 + Green RAL 6029 grating.

Custom colour

We can manufacture in your corporate colour or any BS / RAL colour of your choice. Help to identify contents or hazards with colour. A reduced guarantee may apply on some colours.

(Custom colours not available for the grating support.)



ARK202-FL with anti slip grating support, forklift facility
Spill containment for 2 x 205 litre Drums.

Principal Material	GRP (Glass Reinforced Plastic)
Support Material	Anti slip grating
Dimensions	1380 x 850 x 530mm
Capacity	220 litres
Actual Capacity	270 litres
Maximum Loading	1000 kgs
Weight	approx. 45 kgs
For ambient temperatures	-50°C to +80°C

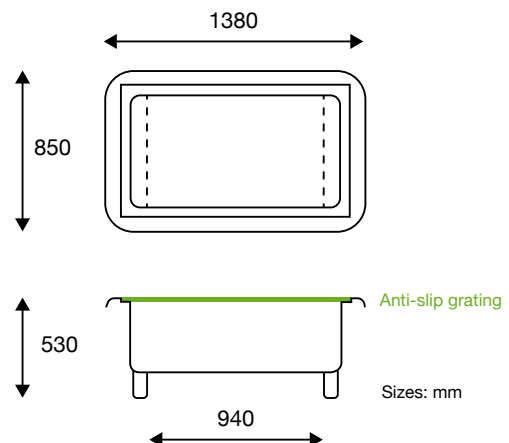

For prices or to order visit: www.arkagriculture.com
or call **01787 220 560** to speak to our specialist team.

4 Drum Bund - ARK203

Spill containment for 4 x 205 litre Drums.

Designed for the long term safe bunding of drums and suitable for all oils and 95% of chemicals, Drum Bunds catch leaks, drips and spills to help you comply with current oil and chemical storage regulations, and keep your storage areas clean.

With unique anti slip grating support surface

The specially designed fibreglass construction is simply shaped with a removable grating support surface, so your bund can be easily emptied or cleaned.

The heavy-duty anti slip gritted grating allows you to position your drums without sliding.

Our product features:

- Tough reinforced composite construction - withstands the rigours of a working environment.
- Broad range chemical compatibility - no need to purchase a new unit if storage use changes.
- Retains long term structural integrity.
- Lighter than steel or polyethylene - easily repositioned without risk of manual handling injury.
- Simply shaped - easily emptied or cleaned.
- Heavy-duty anti slip support surface - position drums without sliding.
- For internal or exterior use.

Benefits:

- Protects the workplace, environment and personnel.
- Maintenance free.

Colour

Blue RAL 5015 + Green RAL 6029 grating.

Custom colour

We can manufacture in your corporate colour or any BS / RAL colour of your choice. Help to identify contents or hazards with colour. A reduced guarantee may apply on some colours.

(Custom colours not available for the grating support.)



ARK203 with anti slip grating support
Spill containment for 4 x 205 litre Drums.

Principal Material	GRP (Glass Reinforced Plastic)
Support Material	Anti slip grating
Dimensions	1380 x 1380 x 220mm
Capacity	220 litres
Actual Capacity	290 litres
Maximum Loading	2500 kgs
Weight	approx. 45 kgs
For ambient temperatures	-50°C to +80°C

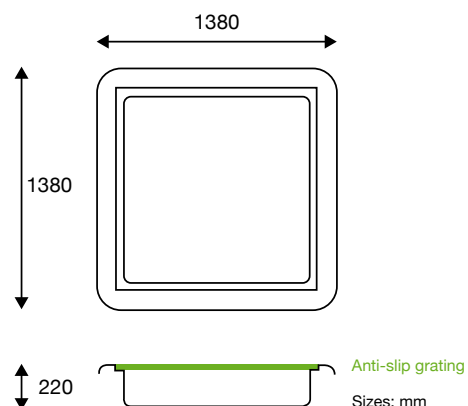

For prices or to order visit: www.arkagriculture.com
or call **01787 220 560** to speak to our specialist team.

4 Drum Spill Pallet with forklift facility - ARK203-FL

Spill containment for 4 x 205 litre Drums.

Designed for the long term safe bunding of drums and suitable for all oils and 95% of chemicals, Drum Bunds catch leaks, drips and spills to help you comply with current oil and chemical storage regulations, and keep your storage areas clean.

With unique forklift facility & anti slip grating features

Specially designed to aid the transportation of your drums, the fibreglass construction is much stronger than polyethylene, both spill pallet and drums can be moved together safely. When using a forklift drum grabber attachment, drums can be positioned without sliding, thanks to the specially gritted grating surface.

Our product features:

- Tough reinforced composite construction - withstands the rigours of a working environment.
- Broad range chemical compatibility - no need to purchase a new unit if storage use changes.
- Retains long term structural integrity.
- Simply shaped - easily emptied or cleaned.
- Heavy-duty anti slip support surface - position drums without sliding.
- Forklift friendly - bund and drums can be lifted together.
- For internal or exterior use.

Benefits:

- Protects the workplace, environment and personnel.
- Maintenance free.

Colour

Blue RAL 5015 + Green RAL 6029 grating.

Custom colour

We can manufacture in your corporate colour or any BS / RAL colour of your choice. Help to identify contents or hazards with colour. A reduced guarantee may apply on some colours.

(Custom colours not available for the grating support.)



ARK203-FL with anti slip grating support, forklift facility
Spill containment for 4 x 205 litre Drums.

Principal Material	GRP (Glass Reinforced Plastic)
Support Material	Anti slip grating
Dimensions	1380 x 1380 x 350mm
Capacity	220 litres
Actual Capacity	290 litres
Maximum Loading	2500 kgs
Weight	approx. 65 kgs
For ambient temperatures	-50°C to +80°C

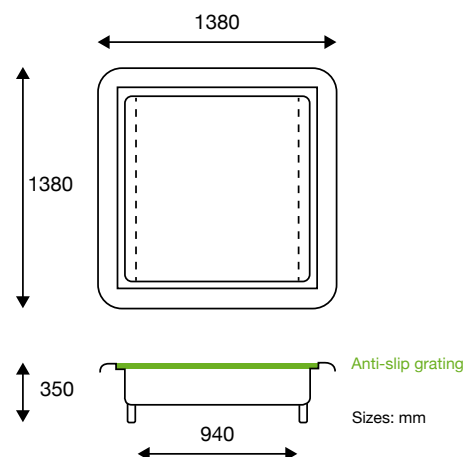

For prices or to order visit: www.arkagriculture.com
or call **01787 220 560** to speak to our specialist team.

7 Drum Spill Tray - ARK205

Spill containment for up to 7 x 205 litre Drums.

Designed for storage of seven drums and suitable for all oils and 95% of chemicals, Drum Spill Trays catch leaks, drips and spills to help you comply with current oil and chemical storage regulations, and keep your storage areas clean.

Ideal for hand barrel trolleys

Specially designed for safe storage of your drums. When using a hand barrel trolley, drums can easily be moved and positioned without sliding, thanks to the specially gritted grating surface.

Our product features:

- Tough reinforced composite construction - withstands the rigours of a working environment.
- Broad range chemical compatibility - no need to purchase a new unit if storage use changes.
- Retains long term structural integrity.
- Simply shaped - easily emptied or cleaned.
- Heavy-duty anti slip support surface - position drums without sliding.
- For internal or exterior use.

Benefits:

- Protects the workplace, environment and personnel.
- Maintenance free.
- Low profile for easy manual loading.

Colour

Blue RAL 5015 + Grey RAL 7035 grating.

Custom colour

We can manufacture in your corporate colour or any BS / RAL colour of your choice. Help to identify contents or hazards with colour. A reduced guarantee may apply on some colours.

(Custom colours not available for the grating support.)



ARK205 with anti slip grating support

Spill containment for up to 7 x 205 litre Drums.

Principal Material	GRP (Glass Reinforced Plastic)
Support Material	Anti slip grating
Dimensions	4300 x 700 x 100mm
Capacity	220 litres
Actual Capacity	250 litres
Maximum Loading	2000 kgs
Weight	approx. 45 kgs
For ambient temperatures	-50°C to +80°C

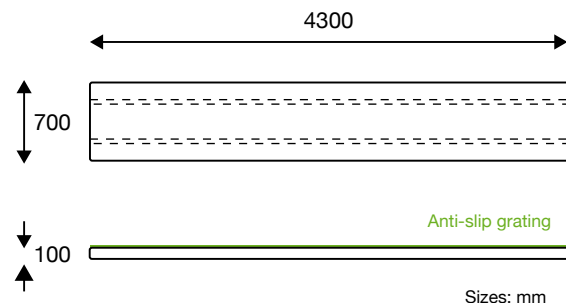

For prices or to order visit: www.arkagriculture.com
or call **01787 220 560** to speak to our specialist team.

ARK Agriculture Ltd,
Milbank House,
Earls Colne Business Park,
Earls Colne, Colchester,
Essex, CO6 2NS

8 Drum Spill Tray - ARK206

Spill containment for 8 x 205 litre Drums.

Designed for storage of eight drums and suitable for all oils and 95% of chemicals, Drum Spill Trays catch leaks, drips and spills to help you comply with current oil and chemical storage regulations, and keep your storage areas clean.

With unique anti slip grating support surface

The specially designed fibreglass construction is simply shaped with a removable grating support surface, so your spill tray can be easily emptied or cleaned.

The heavy-duty anti slip gritted grating allows you to position your drums without sliding.

Our product features:

- Tough reinforced composite construction - withstands the rigours of a working environment.
- Broad range chemical compatibility - no need to purchase a new unit if storage use changes.
- Retains long term structural integrity.
- Lighter than steel or polyethylene - easily repositioned without risk of manual handling injury.
- Simply shaped - easily emptied or cleaned.
- Heavy-duty anti slip support surface - position drums without sliding.
- For internal or exterior use.

Benefits:

- Protects the workplace, environment and personnel.
- Maintenance free.

Colour

Blue RAL 5015 + Green RAL 6029 grating.

Custom colour

We can manufacture in your corporate colour or any BS / RAL colour of your choice. Help to identify contents or hazards with colour. A reduced guarantee may apply on some colours.

(Custom colours not available for the grating support.)



ARK206 with anti slip grating support
Spill containment for 8 x 205 litre Drums.

Principal Material	GRP (Glass Reinforced Plastic)
Support Material	Anti slip grating
Dimensions	1380 x 1380 x 220mm
Capacity	220 litres
Actual Capacity	290 litres
Maximum Loading	2500 kgs
Weight	approx. 45 kgs
For ambient temperatures	-50°C to +80°C

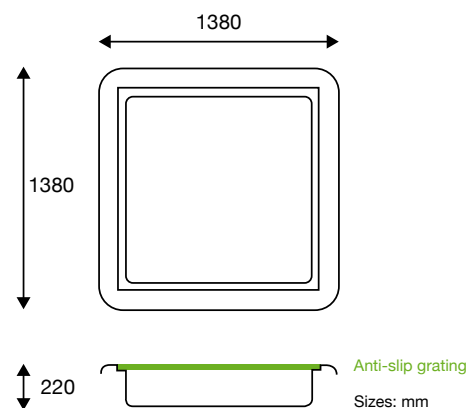

For prices or to order visit: www.arkagriculture.com
or call **01787 220 560** to speak to our specialist team.

ARK Agriculture Ltd,
Milbank House,
Earls Colne Business Park,
Earls Colne, Colchester,
Essex, CO6 2NS

8 Drum Spill Pallet with forklift facility - ARK206-FL

Spill containment for 8 x 205 litre Drums.

Designed for storage of eight drums and suitable for all oils and 95% of chemicals, Drum Spill Pallets catch leaks, drips and spills to help you comply with current oil and chemical storage regulations, and keep your storage areas clean.

With unique forklift friendly & anti slip features

Specially designed to aid the transportation of your drums, the fibreglass construction is much stronger than polyethylene, both pallet and drums can be moved together safely.

When using a forklift drum grabber attachment, drums can be positioned without sliding, thanks to the specially gritted grating surface.

Our product features:

- Tough reinforced composite construction - withstands the rigours of a working environment.
- Broad range chemical compatibility - no need to purchase a new unit if storage use changes.
- Retains long term structural integrity.
- Simply shaped with removable support surface - easily emptied or cleaned
- Heavy-duty anti slip support surface - position drums without sliding.

Benefits:

- Protects the workplace, environment and personnel.
- Maintenance free.

Colour

Blue RAL 5015 + Green RAL 6029 grating.

Custom colour

We can manufacture in your corporate colour or any BS / RAL colour of your choice. Help to identify contents or hazards with colour. A reduced guarantee may apply on some colours.

(Custom colours not available for the grating support.)



ARK206-FL with anti slip grating support, forklift facility
Spill containment for 8 x 205 litre Drums.

Principal Material	GRP (Glass Reinforced Plastic)
Support Material	Anti slip grating
Dimensions	1380 x 1380 x 350mm
Capacity	220 litres
Actual Capacity	290 litres
Maximum Loading	2500 kgs
Weight	approx. 65 kgs
For ambient temperatures	-50°C to +80°C

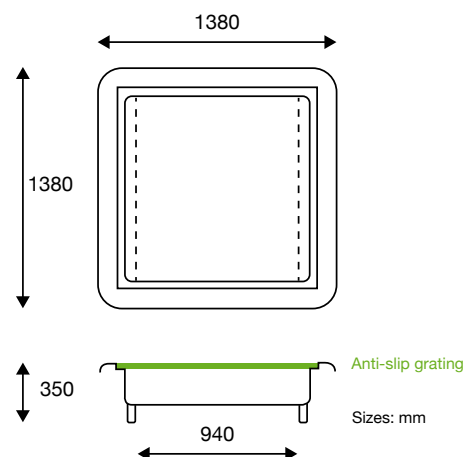

For prices or to order visit: www.arkagriculture.com
or call **01787 220 560** to speak to our specialist team.

ARK Agriculture Ltd,
Milbank House,
Earls Colne Business Park,
Earls Colne, Colchester,
Essex, CO6 2NS

Multi-Purpose Bund, Tank Bund, Generator Bund - ARK301

Spill containment for up to 2000 litres. With 2 supports.

Secondary containment for large tanks, vessels, containers, generators, heavy machinery and leaking equipment.

Designed for the long term safe bunding of vessels, containers, large tanks, generators, heavy machinery and leaking equipment, up to 2000 litres. Suitable for all oils and 95% of chemicals.

Multi-Purpose Tank Bunds catch leaks, drips and spills to help you comply with current oil and chemical storage regulations, and keep your storage areas clean.

Tough reinforced composite construction, with steel supports. Supports can be factory fitted to suit your specific requirements.

Our product features:

- Tough reinforced composite construction - withstands the rigours of a working environment.
- Broad range chemical compatibility - no need to purchase a new unit if storage use changes.
- Retains long term structural integrity.
- Simply shaped - easily emptied or cleaned.
- For internal or exterior use.

Benefits:

- Protects the workplace, environment and personnel.
- Easy to relocate.

Compliance:

- Compliant with 110% oil and chemical storage regulations avoid action from the Environmental Agency.

Colour

Blue RAL 5015.

Custom colour

We can manufacture in your corporate colour or any BS / RAL colour of your choice. Help to identify contents or hazards with colour. A reduced guarantee may apply on some colours.



ARK301 with 2 steel supports

Spill containment for up to 2000 litres.

Principal Material	GRP (Glass Reinforced Plastic)
Support Material	Steel supports
Dimensions	2200 x 2200 x 600mm
Nominal Capacity	2000 litres
Actual Capacity	2250 litres
Maximum UDL	5000 kgs
Weight	approx. 140 kgs

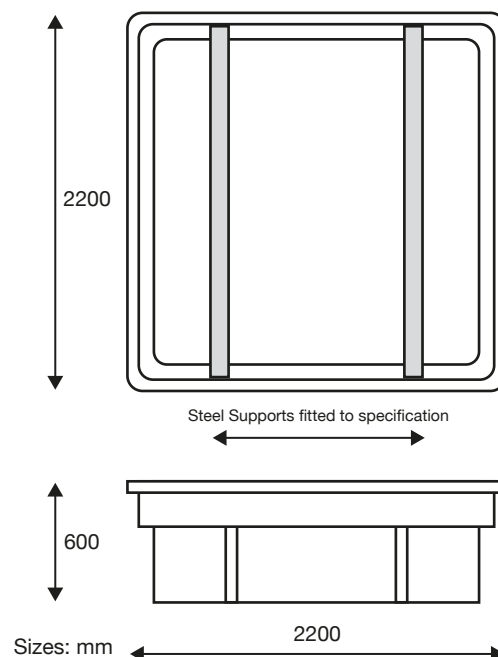

For prices or to order visit: www.arkagriculture.com
or call **01787 220 560** to speak to our specialist team.

Multi-Purpose Bund, Tank Bund, Generator Bund - ARK302

Spill containment for up to 2000 litres. With 3 supports.

Secondary containment for large tanks, vessels, containers, generators, heavy machinery and leaking equipment.

Designed for the long term safe bunding of vessels, containers, large tanks, generators, heavy machinery and leaking equipment, up to 2000 litres. Suitable for all oils and 95% of chemicals.

Multi-Purpose Tank Bunds catch leaks, drips and spills to help you comply with current oil and chemical storage regulations, and keep your storage areas clean.

Tough reinforced composite construction, with steel supports. Supports can be factory fitted to suit your specific requirements.

Our product features:

- Tough reinforced composite construction - withstands the rigours of a working environment.
- Broad range chemical compatibility - no need to purchase a new unit if storage use changes.
- Retains long term structural integrity.
- Simply shaped - easily emptied or cleaned.
- For internal or exterior use.

Benefits:

- Protects the workplace, environment and personnel.
- Easy to relocate.

Compliance:

- Compliant with 110% oil and chemical storage regulations avoid action from the Environmental Agency.

Colour

Blue RAL 5015

Custom colour

We can manufacture in your corporate colour or any BS / RAL colour of your choice. Help to identify contents or hazards with colour. A reduced guarantee may apply on some colours.



ARK302 with 3 steel supports

Spill containment for up to 2000 litres.

Principal Material	GRP (Glass Reinforced Plastic)
Support Material	Steel supports
Dimensions	2200 x 2200 x 600mm
Nominal Capacity	2000 litres
Actual Capacity	2250 litres
Maximum UDL	5000 kgs
Weight	approx. 170 kgs

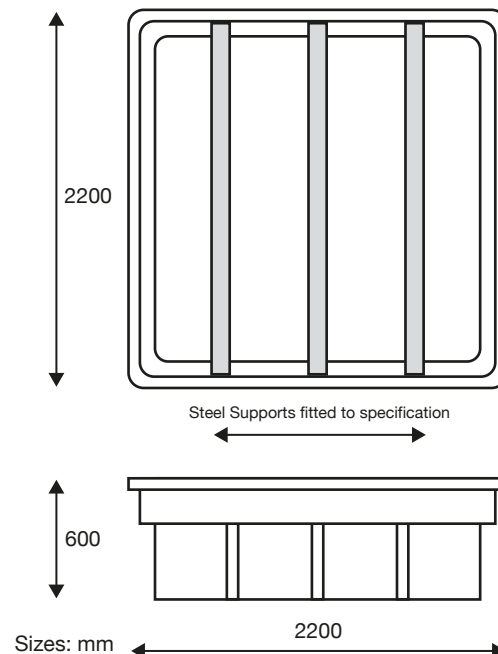

For prices or to order visit: www.arkagriculture.com
or call **01787 220 560** to speak to our specialist team.

Multi-Purpose Bund, Tank Bund, Generator Bund - ARK303

Spill containment for up to 2000 litres. With 4 supports and removable platform.

Secondary containment for large tanks, vessels, containers, generators, heavy machinery and leaking equipment.

Designed for the long term safe bunding of vessels, containers, large tanks, generators, heavy machinery and leaking equipment, up to 2000 litres. Suitable for all oils and 95% of chemicals.

Multi-Purpose Tank Bunds catch leaks, drips and spills to help you comply with current oil and chemical storage regulations, and keep your storage areas clean.

Tough reinforced composite construction, with steel supports. Supports can be factory fitted to suit your specific requirements.

With unique anti slip gritted platform

Simply shaped with a removable grating support surface, so tank bund can be easily emptied or cleaned.

The heavy duty anti slip gritted grating allows you to position tanks without sliding.

Our product features:

- Tough reinforced composite construction - withstands the rigours of a working environment.
- Broad range chemical compatibility - no need to purchase a new unit if storage use changes.
- Retains long term structural integrity.
- Simply shaped - easily emptied or cleaned.
- For internal or exterior use.

Benefits:

- Protects the workplace, environment and personnel.
- Easy to relocate.

Compliance:

- Compliant with 110% oil and chemical storage regulations avoid action from the Environmental Agency.

Colour

Blue RAL 5015 + Green RAL 6029 grating.

Custom colour

We can manufacture in your corporate colour or any BS / RAL colour of your choice. Help to identify contents or hazards with colour. A reduced guarantee may apply on some colours.

(Custom colours not available for the grating support.)



ARK303 with 4 steel supports & removable grating platform
Spill containment for up to 2000 litres.

Principal Material	GRP (Glass Reinforced Plastic)
Support Material	Anti slip grating, steel supports
Dimensions	2200 x 2200 x 625mm
Nominal Capacity	2000 litres
Actual Capacity	2250 litres
Maximum UDL	5000 kgs
Weight	approx. 280 kgs

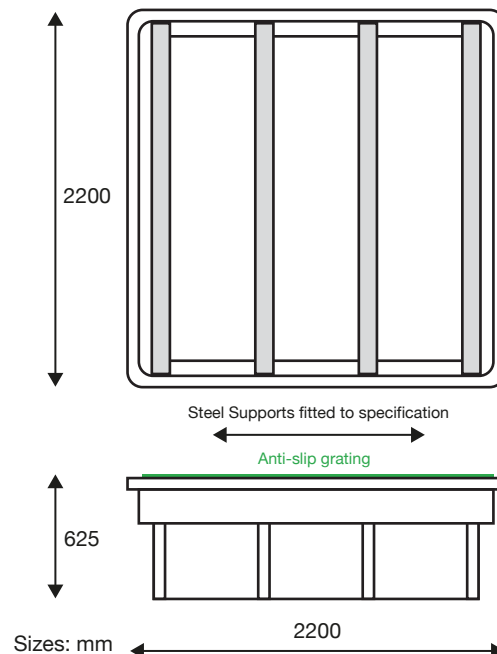

For prices or to order visit: www.arkagriculture.com
or call **01787 220 560** to speak to our specialist team.

Standard Spill Containment Bunds

Spill containment from 1200 - 6720 litres.

The standard bund range has been developed to fulfil spill containment needs of customers who require bunding for permanently sited liquid storage tanks, vessels, and containers etc, specifically those up to 6000 litres in capacity.

Quick and easy to install, available in a range of sizes and capacities, the one piece moulded GRP units are a much more viable long term solution to traditional block, brick or concrete built bunds. Standard Bunds catch leaks, drips and spills to help you comply with current oil and chemical storage regulations, and keep your storage areas clean.

Our product features:

- Tough reinforced composite construction - withstands the rigours of a working environment.
- Broad range chemical compatibility - no need to purchase a new unit if storage use changes.
- Retains long term structural integrity.
- Lighter than steel or polyethylene - easily repositioned without risk of manual handling injury.
- Easy to install.
- Simply shaped - easily emptied or cleaned.
- For internal or exterior use.

Benefits:

- Protects the workplace, environment and personnel.
- Maintenance free.

Compliance:

- Compliant with 110% oil and chemical storage regulations avoid action from the Environmental Agency.

Colour

Blue RAL 5015.

Custom colour

We can manufacture in your corporate colour or any BS / RAL colour of your choice. Help to identify contents or hazards with colour. A reduced guarantee may apply on some colours.



ARK401 - ARK409

Spill containment from 1200 litres, up to 6720 litres.

ARK401	Spill capacity:	1200 litres
	Weight:	approx. 60 kgs
	External dimensions:	3200 x 2200 x 200mm
ARK402	Spill capacity:	1800 litres
	Weight:	approx. 70 kgs
	External dimensions:	3200 x 2200 x 300mm
ARK403	Spill capacity:	2400 litres
	Weight:	approx. 75 kgs
	External dimensions:	3200 x 2200 x 400mm
ARK404	Spill capacity:	1900 litres
	Weight:	approx. 90 kgs
	External dimensions:	4200 x 2600 x 200mm
ARK405	Spill capacity:	2850 litres
	Weight:	approx. 100 kgs
	External dimensions:	4200 x 2600 x 300mm
ARK406	Spill capacity:	3800 litres,
	Weight:	approx. 110 kgs
	External dimensions:	4200 x 2600 x 400mm
ARK407	Spill capacity:	3360 litres
	weight:	approx. 140 kgs
	External dimensions:	6200 x 3000 x 200mm
ARK408	Spill capacity:	5040 litres
	weight:	approx. 155 kgs
	External dimensions:	6200 x 3000 x 300mm
ARK409	Spill capacity:	6720 litres
	weight:	approx. 170 kgs
	External dimensions:	6200 x 3000 x 400mm

For prices or to order visit: www.arkagriculture.com
or call **01787 220 560** to speak to our specialist team.

ARK Agriculture Ltd,
Milbank House,
Earls Colne Business Park,
Earls Colne, Colchester,
Essex, CO6 2NS

Custom Built Bunds & Spill Trays

Tailor made to your exact requirements, our custom built bunds are more economical than you might think. Your bund will be manufactured in a resin finish to suit your specific liquid storage requirements providing you with a cost effective long term solution to your bunding needs.

Additional features can incorporated into the design:-

- Anti slip flooring into the manufacture process.
- Anti slip grating as an internal floor to allow oils or products to flow underneath creating a safer walking surface.
- GRP walkways, platforms or access steps.
- Hazard identification markings.

Our product features:

- Made to suit your exact needs.
- Tough reinforced composite construction - withstands the rigours of a working environment.
- Broad range chemical compatibility - no need to purchase a new unit if storage use changes.
- Retains long term structural integrity.
- Lighter than steel or polyethylene - easily repositioned without risk of manual handling injury.
- Easy to install.
- For internal or exterior use.

Benefits:

- Protects the workplace, environment and personnel.
- Maintenance free.

Compliance:

- Compliant with 110% oil and chemical storage regulations avoid action from the Environmental Agency.

Available in any BS / RAL colour

We can manufacture in your corporate colour or any other colour of your choice. Clearly identify contents or hazards with your bund colour.



Custom bund, 500 x 500 x 500mm.



Hydrochloric acid bunds, 3000 x 2000 x 400mm.



Custom bund, 5000 x 900 x 150mm.

For prices or to order visit: www.arkagriculture.com
or call **01787 220 560** to speak to our specialist team.

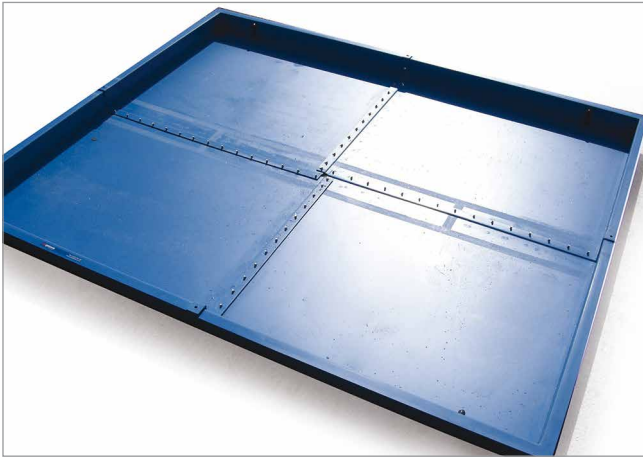

Generator drip tray - manufactured in four sections for ease of installation. 3000 x 2500 x 150mm.



Trifluoroacetic acid tank bund, 3500 x 2500 x 750mm, 6562 litres capacity.



Custom IBC bund for offshore facility, 6000k UDL.



IBC bundstand with customised forklift facility for use with a high lift pallet truck.



Large custom-built oil spill catchment bund for a manufacturing workplace.



Washdown bund with forklift facility.

For prices or to order visit: www.arkagriculture.com
or call **01787 220 560** to speak to our specialist team.

ARK Agriculture Ltd

Milbank House, Earls Colne Business Park, Earls Colne, Essex CO6 2NS

Tel: **01787 220560** Email: **sales@arkagriculture.com**

Website: **www.ARKagriculture.com**